

SHOWER BASES ZEN 6030

LEAK-BARRIER

30" x 59 3/4" x 3"

GENERAL OPTIONS

Acrylic Colors: White,
Biscuit* and Bone* (Allow 3 weeks delivery)

COMPATIBLE DOORS 6030 ALCOVE

AZELIA 60 (front panels only)

Chrome/Clear

SELLA 60 (front panels only)

Chrome/Clear

PRODUCT DESCRIPTION:

Contemporary style

Integrated tiling flange

Acrylic thermoformed and reinforced with fiberglass
Leak-barrier

5 days

BOX SIZE:

60.5" x 31" x 5"

NET WEIGHT:

46 lbs

GROSS WEIGHT:

50 lbs

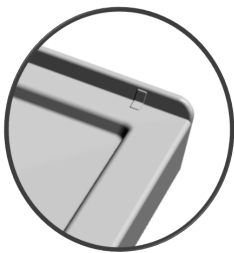

LEAK-BARRIER



21.16310.4582



21.16310.4082



Certification ECORESPONSIBLE

First manufacturer of bathroom products in North America to be certified ecoresponsible.



Produits Neptune

ENTREPRENEUR

6835, Picard street, Saint-Hyacinthe (Quebec) J2S 1H3

Phone: (450) 773-7058 - Fax: (450) 773-5063

produitsneptune.com



Produits Neptune

ENTREPRENEUR

ZEN 6030 D 3B

Base de douche

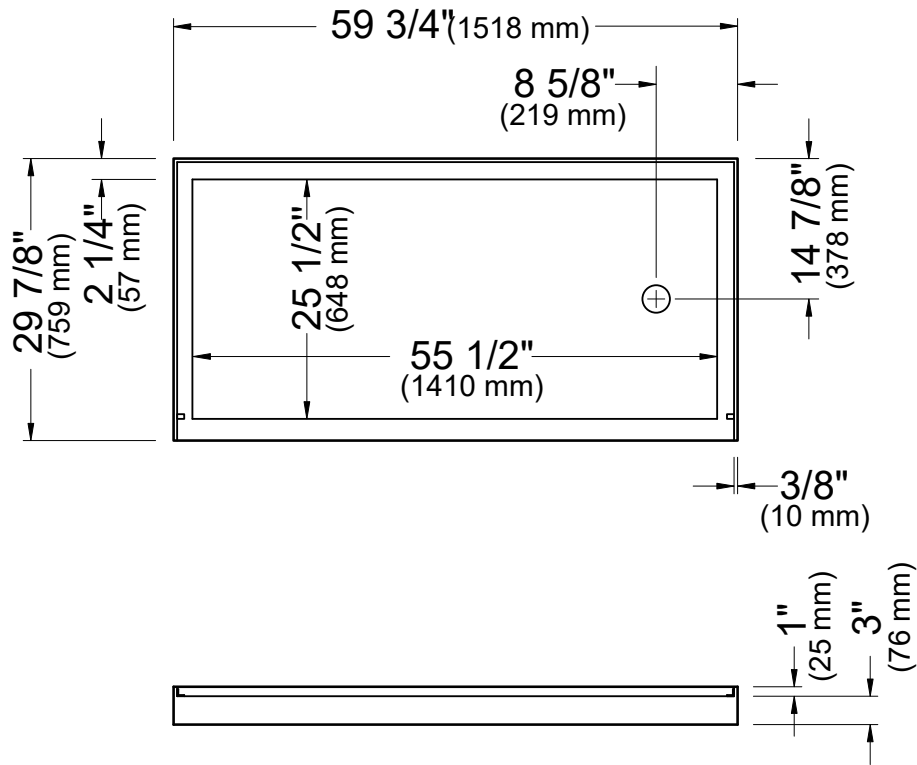

*All dimensions are approximate and subject to change without notice.
Please refer to the installation guide before beginning the installation.



Produits Neptune
ENTREPRENEUR

ZEN 6030 G 3B

Base de douche

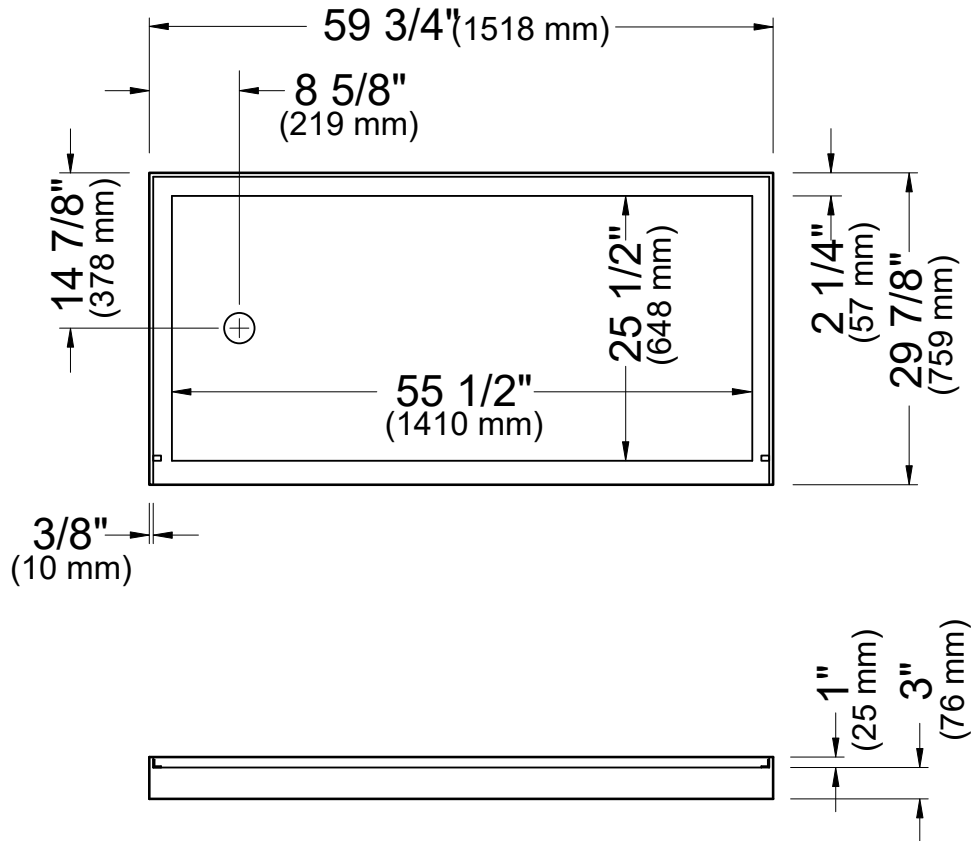

*All dimensions are approximate and subject to change without notice.
Please refer to the installation guide before beginning the installation.